



Ethernet Connect

Service Description

Version 1.6



Table of Content

- 1. INTRODUCTION3**
- 2. TECHNOLOGY4**
- 3. SERVICE DESCRIPTION4**
 - 3.1 AREA OF COVERAGE 4
 - 3.2 TECHNICAL SERVICE DESCRIPTION 4
 - 3.3 APPLICATIONS 5
 - 3.3.1 *Aggregation Scenario based on MEF 33* 5
 - 3.3.2 *Aggregation Scenario based on MEF 6.2* 5
 - 3.3.3 *Leased Line Scenario based on MEF 6.2* 6
 - 3.3.4 *Combinations* 7
 - 3.3.5 *Definition of Access Point and Delivery Point* 7
 - 3.4 VLAN 7
 - 3.5 BANDWIDTH AND ACCESS TECHNOLOGY 9
 - 3.5.1 *Access Bandwidth* 9
 - 3.5.2 *EVC capacity* 9
 - 3.5.3 *Payload* 9
 - 3.6 POLICING AND SHAPING 9
 - 3.7 TECHNICAL SPECIFICATIONS 9
 - 3.7.1 *CoS – Class of Service* 11
 - 3.7.2 *Resilient Access Lines* 12
- 4. REPORTING 13**
- 5. DOCUMENT REFERENCES 15**
- 6. TERMS AND ABBREVIATIONS 15**

1. Introduction

This document is subject to change. Telenor reserves the right to alter the content of this document with the purpose to make further developments, improvements and adjustments, which do not reduce the quality of the services and products. The legally binding version of this document is always the latest official release from Telenor.

Ethernet Carrier is a Layer 2 EVC service based on Telenor's BRUT network:

Some key characteristics of the Ethernet Connect services are:

- *Differentiated access services.*
Access services span from basic connectivity service utilising low cost broadband access networks, to redundant gigabit solutions based on customer-dedicated optical fibres.
- *Class of Service.*
Sensitive traffic on the network can be given the necessary priority in order to prevent delay. Hence, optimizing network usage for the types of applications within an organization.
- *Differentiated SLAs.*
Each access line is delivered with a standard Service Level Agreement (SLA) adapted to the targeted market segment. Improved SLAs are available as an additional service for locations with special requirements.
- *Continuous surveillance.*
Availability of the Ethernet Connect service is under constant monitoring from Telenor's network management centre.
- *Web based reports.*
The web based statistics and monitoring tool Weblines is included in the service. Weblines gives access to administration, network overview and statistics for each site in the customer network.

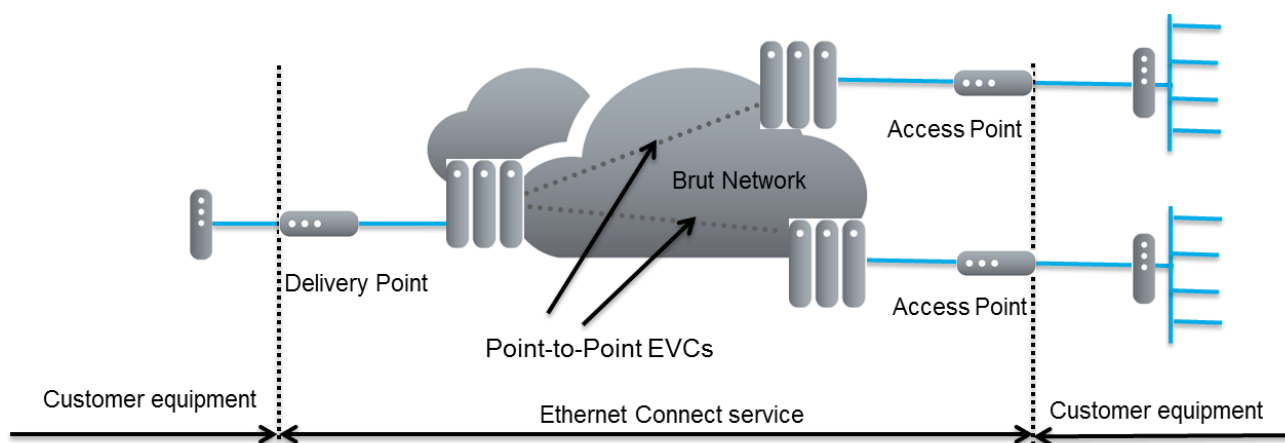

Figure 1 Customer with Ethernet Connect network solution

2. Technology

The EVC-functionality in Telenor's network is based on MPLS (Multi-Protocol Label Switching). MPLS provides strong integrity and security as each EVC has separate routing tables. Traffic in one EVC is totally inaccessible for users of other EVCs. Hence, security against intrusion from undesirable parties is very high.

MPLS is a very flexible technology. An EVC is defined as a logical function in MPLS. Hence, sites can be added, removed and changed in an easy manner.

All customer VLANs are defined as separate EVCs in the Telenor network. On Ethernet links in the access network, traffic in different VLANs is separated according to 802.1Q. On MPLS links in the core network, EVC are separated by the use of MPLS labels. The mapping from VLAN id to MPLS label and vice versa is performed in Telenor's Provider Edge (PE) routers.

The network is designed to handle disruptions between nodes in a fast and effective way. MPLS uses predefined routes in the network to ensure fast reaction when there is a disruption in the underlying layer.

3. Service Description

3.1 Area of Coverage

Ethernet Connect is available in Norway.

3.2 Technical Service Description

The "Ethernet Connect" service is an Ethernet based transmission service, which supports both parts of MEF 33 and MEF6.2.

The MEF 33 service is an E-Access service type. At the UNI, we support both Access-EPL (port based) and Access-EVPL (VLAN based) service. At the ENNI, we support service multiplexing of both Access-EPL and -EVPL.

In addition, the "Ethernet Connect" service support connections between ENNIs when in MEF 33 mode. This enables the customer to set up many combinations of connections to design a network according to specific requirements.

The functional characteristic of a Telenor access point (AP) is similar to UNI and a Telenor Delivery Point (DP) is similar to an ENNI as it is defined in MEF 33.

The MEF6.2 service that is in use is E-Line. It provides tunnels (EVCs) between UNIs. The UNI can either be an AP or a DP (without ENNI-capabilities defined in MEF 33). The service can either be provided as EPL (port-based) or as EVPL (VLAN-based). Use of EVPL will enable service multiplexing. EVPL requires that the VLAN defined is the same on both ends of the EVC. EPL enables only point-to-point

solutions.

3.3 Applications

3.3.1 Aggregation Scenario based on MEF 33

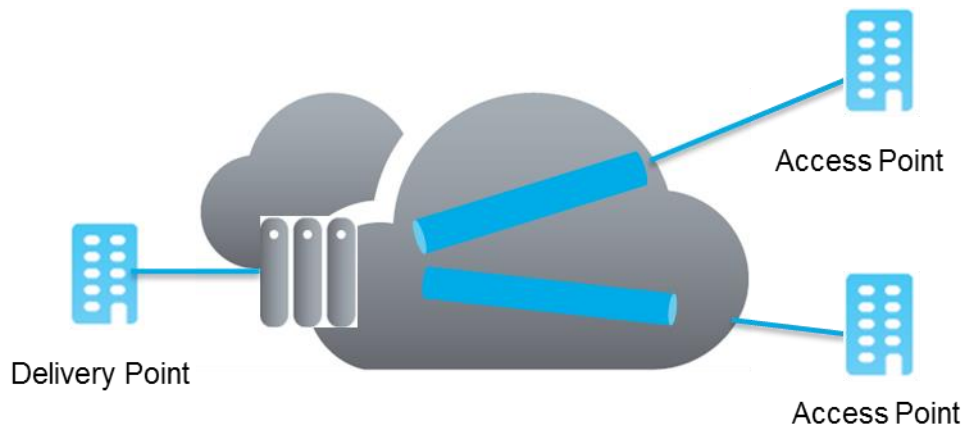

Figure 2: Aggregation Scenario

In this scenario there can be no EVCs from one Access Point to another Access Point. The EVCs can only be set up between an Access Point and a Delivery Point.

One Access Point may have multiple EVC's to several Delivery Points. In addition multiple EVC's can be set up between DP's.

3.3.2 Aggregation Scenario based on MEF 6.2

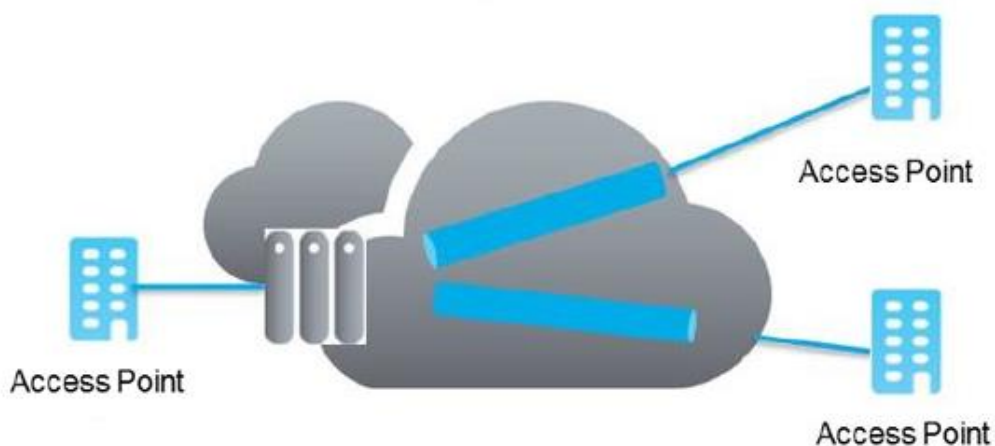

Figure 3: Aggregation Scenario based in MEF 6.2

In the aggregation scenario for the MEF 6.2 service the aggregation UNI can have several EVCs to other UNIs that are set as EVPLs. In this scenario use of EPL is not

possible.

3.3.3 Leased Line Scenario based on MEF 6.2

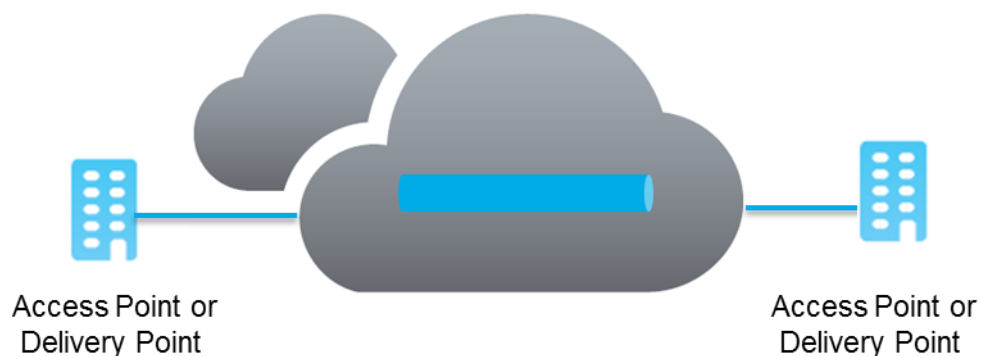

Figure 4: MEF 6.2 Leased Line Scenario

The traffic will be mapped into the EVC based on physical port or S-VLAN. The service is completely transparent to the customer's C-VLANs.

This service is similar to leased lines, with the exception that leased lines have a dedicated capacity while "Ethernet Connect" is based on CoS and statistical multiplexing.

3.3.4 Combinations

The customer can set up a combination of connections to design a network according to specific requirements. The connections can be between APs, AP and a DP, and between DPs.

3.3.5 Definition of Access Point and Delivery Point

The functional characteristic of an AP is similar to the UNI as defined in MEF33 and MEF 6.2. In the untagged version, Access-EPL, all traffic on one port is put into one EVC. In the tagged version, Access-EVPL, C-VLAN is used as identification for which EVC the traffic is intended for. The C-VLAN may be within a range, or a list of values. The C-VLAN will be transported transparently to the DP (ENNI) or AP (UNI).

The functional characteristic of a DP is similar to the ENNI as defined in MEF33. EVCs from both APs and DPs are multiplexed at the DP. We support service multiplexing of both Access-EPL and Access-EVPL. S-VLAN is used as identification for which EVC the traffic is intended for.

3.4 VLAN

Transparency

For the tagged service VLANs 1 & 16 are reserved for Telenor use. In all cases we only look at the outer VLAN tag. The service is transparent for inner VLAN-tags, enabling use of several levels of tagging to be used and the customer has complete control of the use of the inner VLAN-tag.

The port based (VLAN tunneled) service has no such restrictions. All VLANs are transported transparently.

Number of VLANs

For the tagged service:

Max 1000.

The port based (VLAN tunneled) service has no restriction on number of VLANs.

QinQ

The service supports QinQ and is provided as a standard service

QinQ allows customers to run their own VLANs inside Telenor's provided VLAN. It is possible to use QinQ with several levels as part of the standard service.

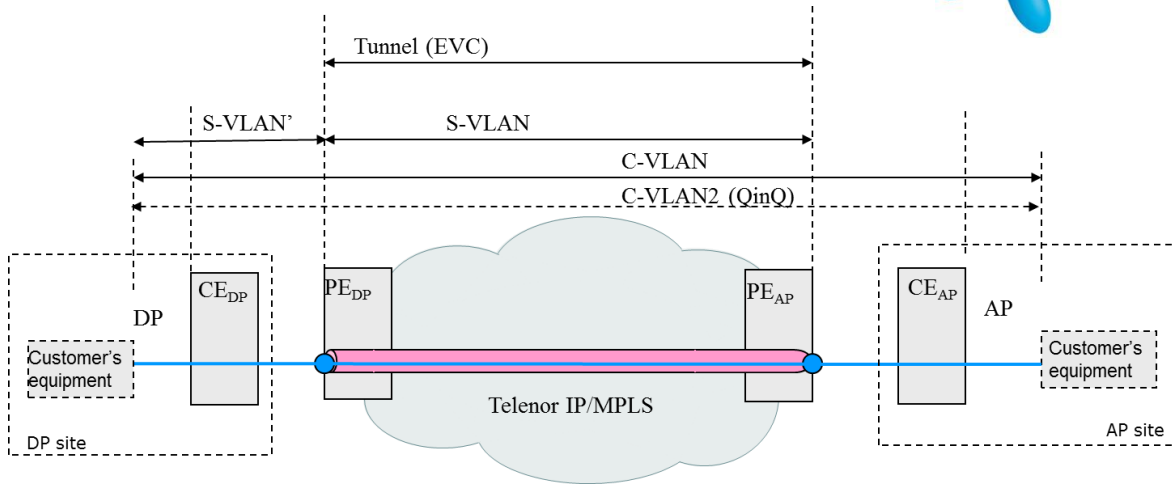

Figure 5: VLAN mapping, DP-AP connections

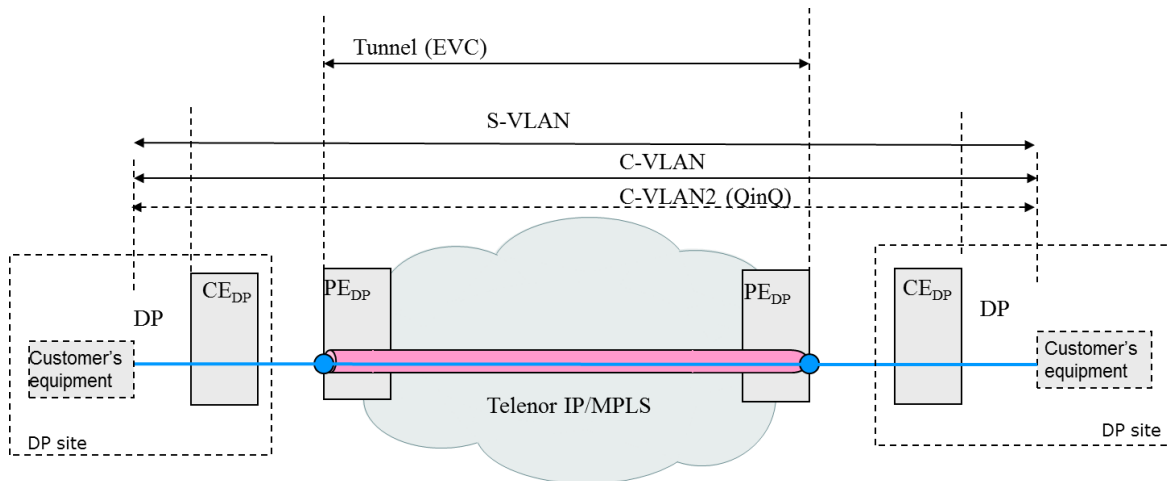

Figure 6: VLAN mapping, DP-DP connections

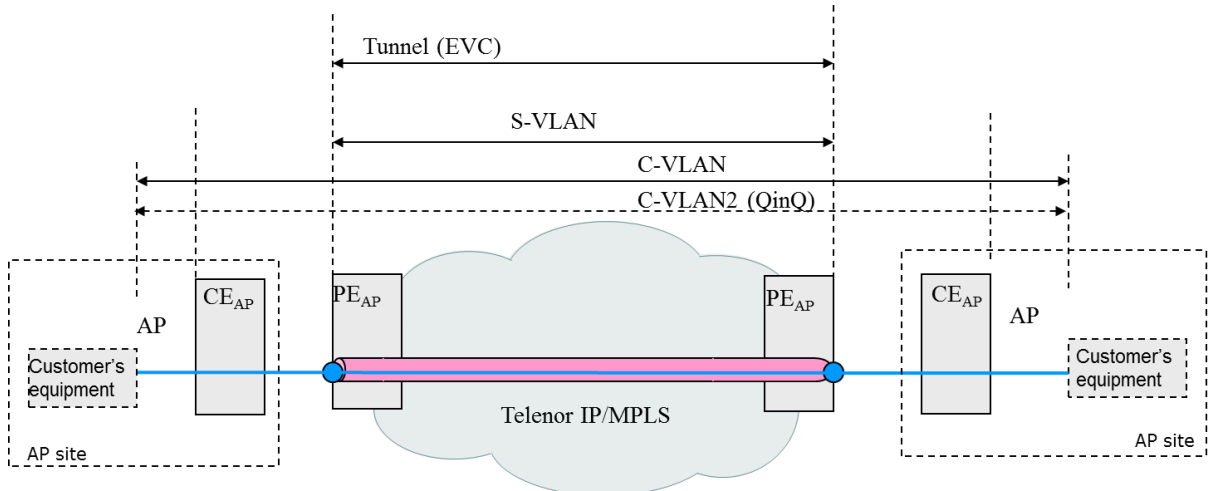

Figure 7: VLAN mapping, AP-AP connections

3.5 Bandwidth and Access Technology

3.5.1 Access Bandwidth

The table provides an overview of the different access types that are used to provide access to Ethernet Connect.

AP		DP		Shaping speed
BW	Access type	BW	Access type	
100M	Fibre			97M
400M	Fibre			400M
1G	Fibre			980M
		10G	Fibre	9800M

Table 1 Bandwidth and Access Technologies

3.5.2 EVC capacity

10M
20M
50M
100M
200M
400M
600M
1G
10G*

Table 2 EVC capacity options * only for DP – DP

3.5.3 Payload

The payload of the EVC cannot exceed the shaping speed of the access ÷ Frame overhead. This depends on Frame size and tagging. The payload is measured on the layer 2 level.

The customer must shape to the agreed Capacity towards the LAN-port. Allowed burst size is set to max. 100 kB.

3.6 Policing and Shaping

The total traffic will be shaped down to the agreed total capacity. The voice class will be policed to the agreed maximum voice capacity.

3.7 Technical Specifications

Area	
General	The service is a layer 2 EVPL service.

Physical interfaces at ENNI (DP)	<p>10GE:</p> <ul style="list-style-type: none"> • 10GBASE-LR and 10GBASE-SR are supported <p>GE:</p> <ul style="list-style-type: none"> • Optical: 1000BASE-LX10 and 1000BASE-SX10 are supported, autoneg enabled • Electrical: 1000BASE-T is supported, full duplex, autoneg enabled <p>Optical connector: LC connector.</p> <ul style="list-style-type: none"> • GLC-LH-SMD-C
Physical interfaces at UNI (AP)	<p>GE:</p> <ul style="list-style-type: none"> • Optical: 1000BASE-LX10 and 1000BASE-SX10 are supported, autoneg enabled • Electrical: 1000BASE-T is supported, full duplex, autoneg enabled <p>FE:</p> <ul style="list-style-type: none"> • Optical: 100Base-LX10 and 100BASE-FX are supported, autoneg enabled • Electrical: 100Base-TX is supported, full duplex, autoneg disabled <p>Optical connector: LC connector</p> <ul style="list-style-type: none"> • GLC-LH-SMD-C
MTU at AP / DP	<p>MTU: 1950 Bytes for 10M – 10G (fiber)</p> <p>Jumboframes up to 9.000 Bytes on DP – DP solutions</p>
MAC-addresses	More than 1000
L2CP	<p>Layer 2 control protocols are not supported (discard).</p> <p>Customers requiring L2CP must use tunnelling on their own equipment.</p>
Policing and shaping	<p>The total access bandwidth at the UNI/ENNI and the individual EVC tunnel bandwidth will both be shaped to agreed bandwidth.</p> <p>The voice class will be policed to the agreed maximum voice capacity (25% or 50%). This applies to the total access bandwidth at the UNI/ENNI, and not each EVC tunnel.</p>
Resilience	<p>The service may be combined with the add-on services «Spredt routing» and «Alternativ fremføring», ensuring diversified routing. The service does not support any failover mechanisms.</p>
Transparency	The service is transparent to IEEE 802.1ag / ITU-T Y.1731.
Transparency	The service is transparent to 802.1p.

Transparency	The service is transparent to 802.1q.
Transparency	The service is transparent to the following protocols: CDP, LLDP, STP, VTP, PAGP, LACP og UDLD

Table 3: Technical Requirements

IEEE 802 protocols:

IEEE 802.3u - 100BASE-TX, 100BASE-FX Fast Ethernet at 100 Mbit/s w/auto-negotiation

IEEE 802.3z - 1000BASE-X, Gbit/s Ethernet over Fiber-Optic at 1 Gbit/s

IEEE 802.3ab - 1000BASE-T, Gbit/s Ethernet over twisted pair at 1 Gbit/s

IEEE 802.3ae – 10Gbase, 10 Gbit/s Ethernet over optical fiber

IEEE 802.1Q – Standard for VLAN tagging

3.7.1 CoS – Class of Service

The product can be delivered with CoS on the access service. The customer can choose between 25 or 50% CIR.

The following CoS mapping will be used based om customers P-bit setting.

P bit	Voice	Best effort	Premium
5	X		
0		X	
Else			X

Table 4: Class of Service

The service can act on the customer's p-bit on outer tag, if QoS is selected.

A CVLAN tunnelled service, will be provided as a single CoS transported as premium class.

3.7.1.1 Technical service parameters

The Ethernet Connect service offers SLA parameters for the following elements related to CoS:

- Delay
- Jitter
- Packet loss

Refer to SLA documentation for a description of values and conditions for these parameters.

3.7.2 Resilient Access Lines

The product can be delivered with separate resilient access lines. The options available are illustrated in the drawings below. There is no failover mechanism between the access lines included or the layer 2 service. This logical failover mechanism must be handled by the customer. The backbone network is fully meshed with rerouting mechanism.

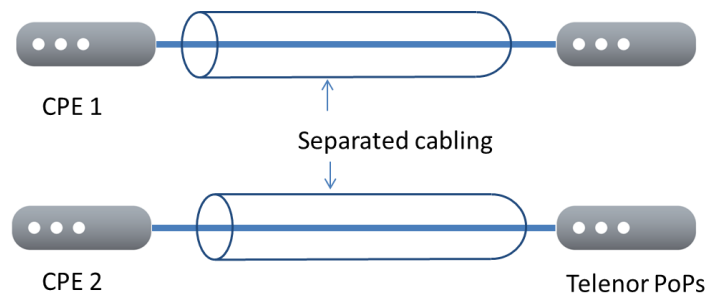
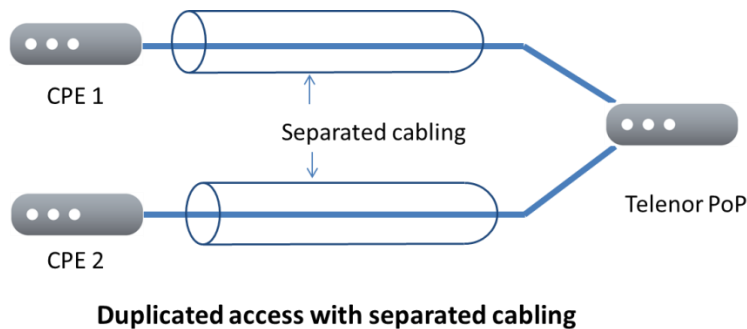
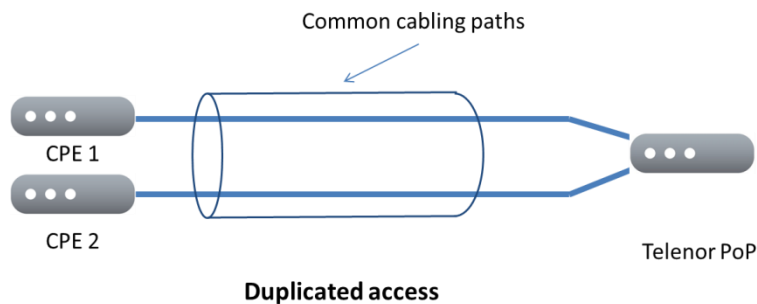
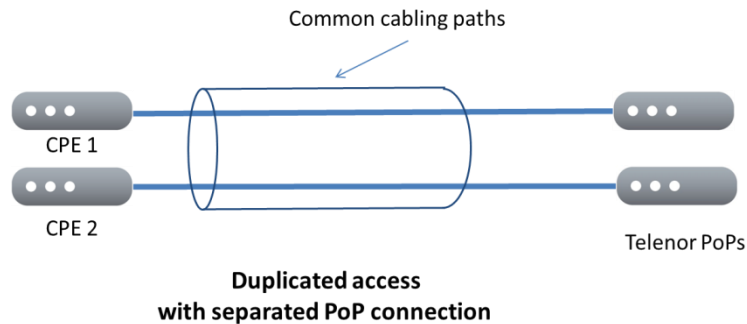

Fig 8 Resilient access options

4. Reporting

Webline is a tool for administration and statistics of the Ethernet Connect service. A limited version of Webline is included with the Ethernet Connect service.

Webline for Ethernet Connect includes the following services:

- An interface for administration and classification of Webline users.
- Overview of the customer network solution
- Administrative view of each customer site
- Detailed technical parameters for each site
- Tables that displays technical availability and downtime
- Graph showing traffic statistics.
- A looking-glass function that provides access to certain functions in the customer located router.

Statistics for interface TenGigabitEthernet1/1 for Telenor Norge as div. Wholesale Retail

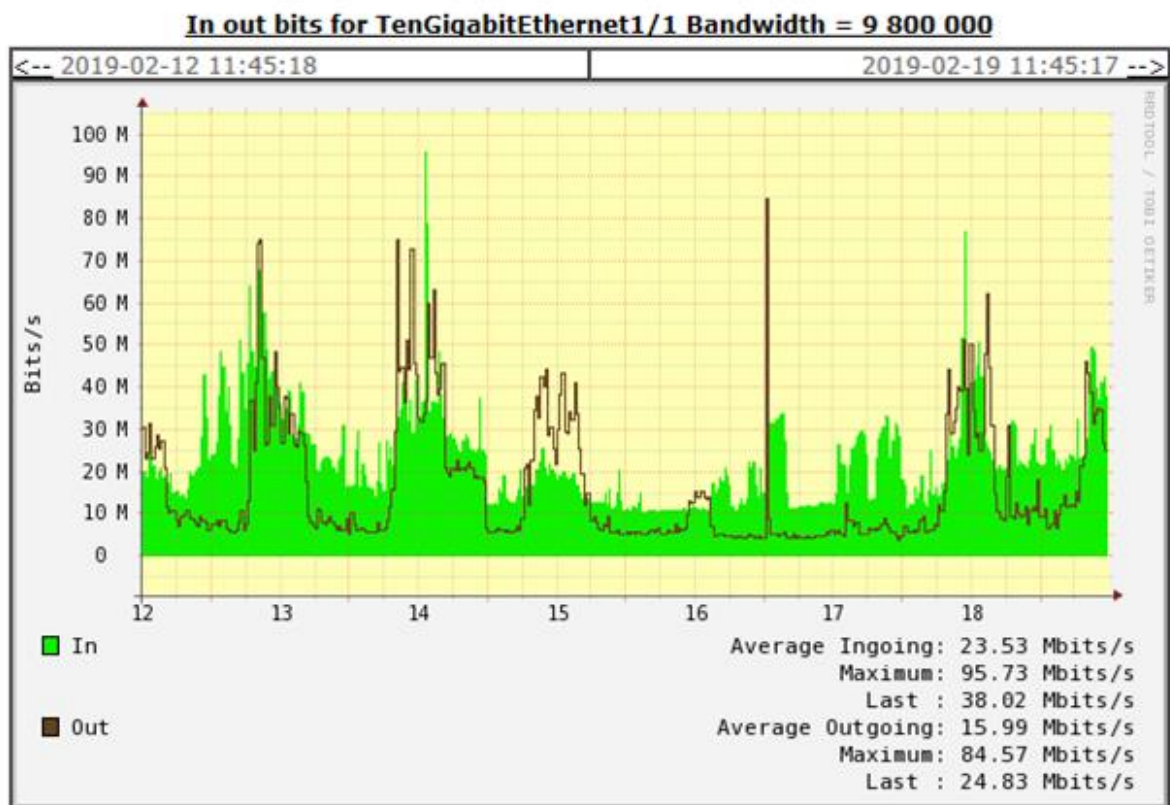

Figure 9 Screen shot of Webline, Overall traffic on one access

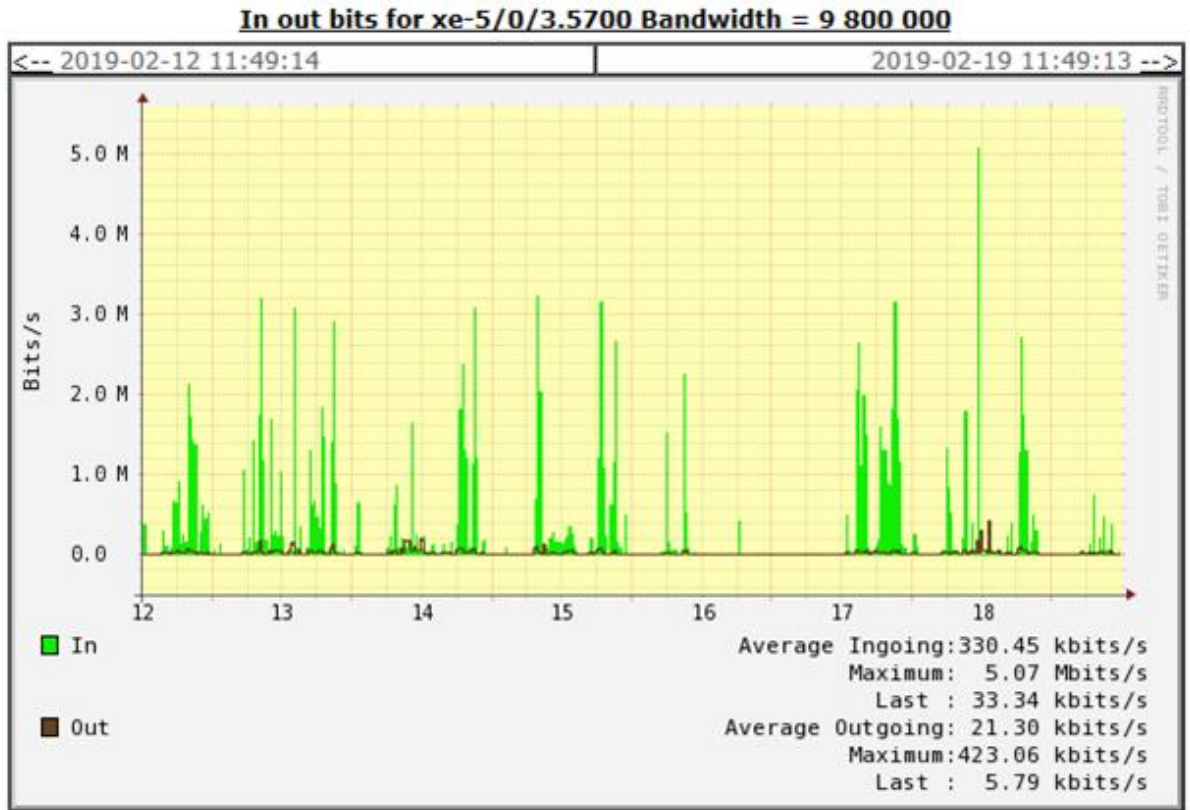

Figure 10 Screen shot of Webline, Traffic related to one single VPN on the access in figure 9

5. Document references

- [1] Service Level Agreement for Ethernet Connect
- [2] User Manual for Weblane

6. Terms and abbreviations

AP	Access Point, location where the customer's access node is connected to the Ethernet Backhaul.
CoS	Class of Service
CVLAN	Customer VLAN
CPE	Customer Premises Equipment
C-Tag	Subscriber VLAN Tag
DP	Delivery Point, the central access point of the customer where the customer connects to the L3 and is the main access for the backhaul. It is possible to have several DPs at the same physical location.
ENNI	External Network Network Interface
EVC	Ethernet Virtual Connection
EPL	Ethernet Private Line
EVPL	Ethernet Virtual Private Line
FE	Fast Ethernet
GbE	Gigabit Ethernet
LAN	Local Area Network
LL	Leased Line
Mbps	Megabit per second
MPLS	Multi Protocol Label Switching
ODP	Operator Delivery Point. Telenor's main location for the final IP/MPLS node (edge node) towards the customer is located. ODP and DP are identical points in the case where customer equipment is co-located
PE	Provider Edge
SVLAN	Service VLAN
SLA	Service Level Agreement
S-Tag	Service VLAN Tag
UNI	User Network Interface
VLAN	Virtual Local Area Network