

TELENOR

SPECIFICATION

Specification no.: OA 307

Edition: 4.4

In force from: 01.01 2006

**Requirements for equipment to be
connected to the local sub-loop in the
access network of Telenor.
SHDSL equipment providing Nx64 kbit/s
digital transmission, full unbundled
access (service type G_{DF})**

Document ID : TNO-FX-PT-I&P/OA307/2311 2005

Archive no. :

Index words : Access network, copper pairs, LLUB, equipment requirements, NX64 kbit/s

Abstract : Requirements for the equipment of an Operator leasing copper pairs in the access network of Telenor in order to provide Nx64 kbit/s digital transmission

Telenor
N-1331 Fornebu, Norway
Telephone: +47 810 77 000

TELENOR SPECIFICATION		
Specification OA 307	Requirements for equipment to be connected to the local sub-loop in the access network of Telenor. SHDSL equipment providing Nx64 kbit/s digital transmission, full unbundled access (service type G_{DF})	
Date: 23.11 2005	Edition: 4.4	Page: 2 of 8

CONTENT

1	SCOPE	3
2	REFERENCES	3
2.1	NORMATIVE REFERENCES.....	3
2.2	INFORMATIVE REFERENCES	3
3	DEFINITIONS AND ABBREVIATIONS	4
4	APPLICATION	4
4.1	PROVISION OF SHDSL SYSTEM	4
5	GENERAL REQUIREMENTS	5
6	TRANSMISSION SYSTEM	5
7	ELECTRICAL CHARACTERISTICS	5
7.1	GENERAL.....	5
7.2	REMOTE FEEDING	5
7.3	TRANSMITTER/RECEIVER IMPEDANCE AND RETURN LOSS.....	6
7.4	PSD MASKS	6
7.5	POWER BACK-OFF	6
7.6	UNBALANCE ABOUT EARTH.....	6

Annex 1: Document history

Annex 2: Statement of Compliance

TELENOR SPECIFICATION		
Specification OA 307	Requirements for equipment to be connected to the local sub-loop in the access network of Telenor. SHDSL equipment providing Nx64 kbit/s digital transmission, full unbundled access (service type G_{DF})	
Date: 23.11 2005	Edition: 4.4	Page: 3 of 8

1 Scope

This specification gives requirements for equipment owned by Operator and intended for connection to local loop in the access network of Telenor. The requirements apply for SHDSL equipment supplying Nx64 kbit/s bit stream for duplex and symmetrical operation on single copper pair in the range of 192 kbit/s to 2 312 kbit/s using Trellis pre-coding and pulse amplitude modulation (TC-PAM). There are 3 classes of service:

- G1 ≤ 648 kbit/s
- G2 ≤ 1 224 kbit/s
- G3 ≤ 2 320 kbit/s

Since SHDSL is spectrally incompatible with other xDSL systems (eg. ADSL) from bit rate 1 224 kbit/s and above, it is mandatory to implement the Power Back-off function in 7.5.

The Operator is responsible that the equipment is in conformance to this specification.

For equipment to be installed in Telelosji the formulary ‘Statement of Compliance’ in annex 2 shall be completed and forwarded to Telenor.

2 References

This specification incorporates by dated or undated references, provisions from other publications/standards. These normative references are cited at the appropriate places in the text and the references are listed hereafter. For dated references, subsequent amendments to or revisions of any of these publications apply to this specification only when incorporated in it by amendment or revision. For undated references, including amendments, the last edition of the document referred to applies.

2.1 Normative references

- [1] ITU-T G.991.2: “*Single-pair high-speed digital subscriber line (SHDSL)*”
- [2] Telenor Specification OA 100: “*General requirements for equipment to be connected to the local loop in the access network of Telenor and/or material and equipment to be installed and operated in Telelosji*”

2.2 Informative references

- [3] Telenor Nett Specification A59 (2001-05): “*Access to copper pairs in the access network of Telenor. Specification of the network side of the user-network interface*”
- [4] Telenor Specification OA 104 (2006-01): “*Requirements for equipment to be connected to the local loop in the access network of Telenor. HDSL equipment providing Nx64 kbit/s digital transmission, full unbundled access (service type D_{AF})*”

TELENOR SPECIFICATION		
Specification OA 307	Requirements for equipment to be connected to the local sub-loop in the access network of Telenor. SHDSL equipment providing Nx64 kbit/s digital transmission, full unbundled access (service type G_{DF})	
Date: 23.11 2005	Edition: 4.4	Page: 4 of 8

3 Definitions and abbreviations

Telelosji	Colocation at the premises of Telenor
Operatøraksess	Operators' access to the access network of Telenor
DB	Distribution Box
HDSL	High bit rate Digital Subscriber Line
MDF	Main Distribution Frame
NTP	Network Termination Point
SHDSL	Single-Pair High-Speed Digital Subscriber Line
STU	SHDSL Transceiver Unit
TC-PAM	Trellis Coded Pulse Amplitude Modulation
xDSL system	Any type of digital transmission system for the subscriber loop

4 Application

This specification applies to a SHDSL system provided by Operator. Operator's SHDSL access node is placed in the vicinity of a distribution box (DB) and the far end SHDSL transceiver unit at the subscriber's premises as shown in figure 1. A one pair transmission system shall be used.

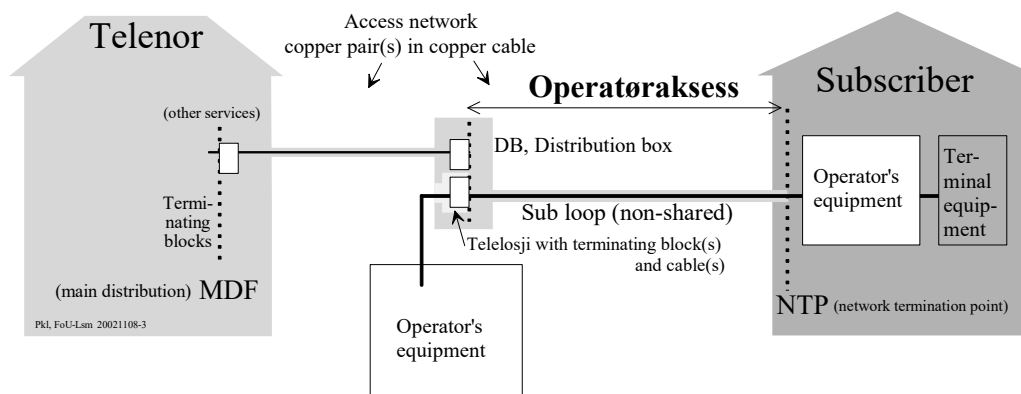

Figure 1 Configuration of the access network.

4.1 Provision of SHDSL system

If SHDSL systems from Operator are directly attached to the distribution box it will introduce interference conflicts that is elsewhere not present in the access network of Telenor. Such an implementation has to take care of existing SHDSL, HDSL and VDSL connections or other transmission systems supported from the MDF at the central office (see figure 1). Operatøraksess may as well be present from the same MDF.

The transmit level from the SHDSL modem in the vicinity of the DB must be limited, and the

TELENOR SPECIFICATION		
Specification OA 307	Requirements for equipment to be connected to the local sub-loop in the access network of Telenor. SHDSL equipment providing Nx64 kbit/s digital transmission, full unbundled access (service type G_{DF})	
Date: 23.11 2005	Edition: 4.4	Page: 5 of 8

allowed range must be limited too.

If the distance from DB to the closest MDF ($l_{\text{MDF-DB}}$) is less than a specific limit, SHDSL transmission systems may be installed according to this specification.

If the distance from DB to the closest MDF ($l_{\text{MDF-DB}}$) is greater than a specific limit, SHDSL transmission systems can not be deployed due to technical limitations (interference with existing services).

The distance between MDF and DB, $l_{\text{MDF-DB}}$, shall not exceed 85 % of the range limit stated for the actual service type (eg. G1, G2 and G3).

Note! The range limits recommended for G1, G2 and G3 are respectively 2,5 km, 1,8 km and 1,2 km.

5 General requirements

All installed equipment operating in Telelosji or used for Operatøraksess shall fulfil requirements stated in Telenor Specification OA 100 [2] related to:

- safety
- environmental conditions
- documentation.

6 Transmission system

The SHDSL transceivers shall operate using Trellis Coded Pulse Amplitude Modulation (TC-PAM) line code. This specification specifies a two-wire operational mode SHDSL-system that is capable of supporting user data rates from 192 kbit/s to 2 312 kbit/s ($n \times 64 + i \times 8$ kbit/s, where $3 \leq n \leq 36$ and $0 \leq i \leq 7$. For $n=36$, i is restricted to the values of 0 or 1.

In ITU-T G.991.2 [1] the Annexes F and G shall not be used in the access network of Telenor.

*Note! Annex F: "Region 1 requirements for payload data rates up to 5696 kbit/s"
Annex G: "Reserved for Region 2 requirements for data rates between 2320 kbit/s and **max rate**"*

7 Electrical characteristics

7.1 General

Equipment for G1, G2 and G3 shall satisfy the relevant requirements for the transceiver specified below. The requirements refer to ITU-T G.991.2 [1], clause 11.

7.2 Remote feeding

The feeding voltage shall not exceed -110 V. In this case the feeding voltage on both feeding leads shall be non-positive referred to ground potential.

Note! The feeding voltage may be symmetrical with ± 55 V referred to ground.

The feeding current shall not exceed 40 mA.

TELENOR SPECIFICATION		
Specification OA 307	Requirements for equipment to be connected to the local sub-loop in the access network of Telenor. SHDSL equipment providing Nx64 kbit/s digital transmission, full unbundled access (service type G_{DF})	
Date: 23.11 2005	Edition: 4.4	Page: 6 of 8

7.3 Transmitter/receiver impedance and return loss

The nominal driving point impedance at the line side and the return loss shall be according to ITU-T G.991.2 [1], subclause 11.3 and Annex B.5.2.

7.4 PSD masks

For all data rates, the measured transmit PSD of each STU shall not exceed the PSD symmetrical masks specified in ITU-T G.991.2 [1], Annex B.4.1.

7.5 Power Back-off

The Power Back-off function is implemented to reduce crosstalk impairments to other transmission systems utilizing the same cable. The Power Back-off function defined in ITU-T G.991.2 [1], subclause 6.4.1.10 is mandatory.

7.6 Unbalance about earth

The longitudinal conversion loss (LCL) shall meet the requirement of 40 dB as defined in accordance to conformance tests specified in ITU-T G.991.2 [1], subclause 11.1 and regional requirements defined in ITU-T G.991.2 [1], subclause B.5.4.

The longitudinal component of the output signal shall be in accordance to conformance tests specified in ITU-T G.991.2 [1], subclause 11.2 and regional requirements defined in ITU-T G.991.2 [1], subclause B.5.5.

Telenor
N-1331 Fornebu Norway
Telephone: +47 810 77 000

TELENOR SPECIFICATION			
Specification OA 307	Requirements for equipment to be connected to the local sub-loop in the access network of Telenor. SHDSL equipment providing Nx64 kbit/s digital transmission, full unbundled access (service type G_{DF})		
Date: 23.11 2005	Edition: 4.4	Annex 1	Page: 1

Annex 1: Document history

Edition	Published	Comments
1.0	01.11.01	Kjell E. Sterten, TTS-NL-I-P
2.0	01.02.02	Kjell E. Sterten, TTS-NL-I-P
3.0	31.12.02	Jon Weberg, NL-I-AN
4.0	01.01 2004	Kjell E. Sterten, TN-NL-U-T
4.1	01.01 2005	Heidi Eide, TN-SMP
4.2	01.03 2005	Kjell E. Sterten, TN-NL-U-T
4.3	31.10 2005	Kjell E. Sterten, TNO-FX-PT-I&P
4.4	23.11.2005	Kjell E. Sterten, TNO-FX-PT-I&P

STATEMENT OF COMPLIANCE

**TELENOR
Specification OA 307**

Requirements for equipment to be connected to the local sub-loop in the access network of Telenor. SHDSL equipment providing Nx64 kbit/s digital transmission, full unbundled access (service type G_{DF})

Date: 23.11 2005

Edition: 4.4

Annex 2

Page: 1

Date:

Operator:

System identification (vendor, model, type):

Connection to the access network of Telenor: Yes (direct)..... Indirect (aux. equip.).....

The given information is valid.

Date/Signature: _____

(sign.)

FC = Fully compliant NC = Non-compliance

Clause no.	Description	Statement of Compliance		Remarks and additional information	For internal use
		FC	NC		
1	Scope	<input type="checkbox"/>	<input type="checkbox"/>		
2	References				
2.1	Normative references	<input type="checkbox"/>	<input type="checkbox"/>		
2.2	Informative references	<input type="checkbox"/>	<input type="checkbox"/>		
3	Definitions and abbreviations	<input type="checkbox"/>	<input type="checkbox"/>		
4	Application	<input type="checkbox"/>	<input type="checkbox"/>		
4.1	Provision of SHDSL system	<input type="checkbox"/>	<input type="checkbox"/>		
5	General requirements	<input type="checkbox"/>	<input type="checkbox"/>		
6	Transmission system	<input type="checkbox"/>	<input type="checkbox"/>		
7	Electrical characteristics				
7.1	General	<input type="checkbox"/>	<input type="checkbox"/>		
7.2	Remote feeding	<input type="checkbox"/>	<input type="checkbox"/>		
7.3	Transmitter/receiver impedance and return loss	<input type="checkbox"/>	<input type="checkbox"/>		
7.4	PSD masks	<input type="checkbox"/>	<input type="checkbox"/>		
7.5	Power Back-off	<input type="checkbox"/>	<input type="checkbox"/>		
7.6	Unbalance about earth	<input type="checkbox"/>	<input type="checkbox"/>		